



40" ROTARY MOWER
&
50" ROTARY MOWER
OPERATORS MANUAL

FORM NO: 39003 (7-85)

PART NO: 39000 - 40"
PART NO: 38994 - 50"

PRINTED IN USA

NOTE

Read this manual carefully and learn to operate and service your 40"/50" Rotary Mower before using it.

To keep the warranty, the 40"/50" Rotary Mower must be maintained and operated as directed in this manual.

All references to "left-side", "right-side", "front", and "back" are given from the operator's position.



Look for this symbol to point out important safety precautions. It means -- ATTENTION! BECOME ALERT! YOUR SAFETY IS INVOLVED.

SECTION 1

Instructions for Safe Operation

CONTENTS

1. INSTRUCTIONS FOR SAFE OPERATION
2. OPERATING INSTRUCTIONS
3. SERVICE INSTRUCTIONS
4. STORAGE
5. SOLVING PROBLEMS
6. ILLUSTRATED PARTS AND PARTS LIST
7. SPECIFICATIONS
8. SET-UP INSTRUCTIONS
9. WARRANTY

SECTION 1

Instructions for Safe Operation

Improper use of this equipment can injure people and damage the equipment. People using or servicing this equipment must read and follow the instructions in this manual.

It is important to understand that this manual and any other Gravely instruction manuals do not cover every possible danger. It is impossible for Gravely to know all possible dangers in operating and servicing the equipment.

The purchaser must give these instructions to the people operating and maintaining this equipment. These people must use eye and foot protection.

1.1 Preparation:

1. Read this manual and the tractor manual carefully.
2. Learn the location and function of all controls.
3. Learn how to use the controls to stop the wheels and mower quickly.
4. Use caution with gasoline. Gasoline is very flammable. Keep it in a clean and tight container away from flames or hot items. Never put gasoline in the fuel tank while the engine is running or hot. Clean up spilled gasoline before starting engine.
5. Be certain that all shields, guards, and interlock switches are in the correct positions.
6. Never permit children to operate the tractor and mower.
7. Inspect area to be mowed and remove all material which could be thrown by the mower.
8. Before starting the engine, put the PTO control lever in the "OFF" position and the gear shift lever in the neutral "N" position.
9. When hauling the equipment, connect the chassis to the transporting vehicle. Never connect from control levers, rods, or like items that could be damaged.
10. Replace all parts that become damaged or lost.

1.2 Operation:

1. Wear foot and eye protection. Do not wear loose clothing.
2. Do not use the equipment in the dark without adequate lighting.
3. Keep the equipment in good condition. Maintain it as directed in this manual.
4. USE ONLY GRAVELY ACCESSORIES AND ATTACHMENTS.
5. Do not overspeed the engine. Do not override the governor.
6. Keep away from moving parts.
7. Keep people and animals away from the operating area.
8. Do not let people other than the operator near the operating equipment.
9. Use a slow speed and engage the direction control lever slowly when operating on slopes.
10. Look for and keep away from hazards.
11. After hitting an object, stop the equipment and engine. Check for damage. Repair any damage before operating.
12. Look behind when operating in reverse. Look for people and hazards.
13. Operate only from the operator's position, just behind the handlebars or on the tractor seat.
14. Travel across slopes with the walk-behind tractor. Travel up and down slopes with the ride-on tractor.
15. If there is a sudden change in the sound or vibration of the equipment, stop the engine and check for damage. Repair any damage or failure before continuing operation.
16. Never run the engine indoors except to move it outside. Exhaust fumes are dangerous.
17. Go slowly on slick surfaces.
18. Follow traffic laws when operating on or near a road.
19. Before making adjustments or servicing, move the PTO to "OFF," turn the ignition switch to "OFF," and wait until all moving parts completely stop.
20. Before leaving the operator's position, put the PTO lever in the "OFF" position, turn the ignition key to the "OFF" position. Move the direction control lever to forward position (walk-behind tractor). Set the brake lock for parking (ride-on tractor).

SECTION 2

Operating Instructions

- 2.1 Transport the equipment to the area to be mowed.
- 2.2 Inspect the area to be mowed and remove all material which could be thrown by the mower.
- 2.3 Plan the pattern for cutting the grass. Generally an area is mowed around the periphery towards the center by discharging the grass toward the center on the first pass. The remainder of the mowing is done discharging the grass outward in the area which has been cut.
- 2.4 See Section 7 for the schedule of heights of cut. Set the mower for the height of cut desired.
- 2.5 See the tractor manual for correct operation of the PTO. Start the engine and put the PTO control in the "ON" position. Move the throttle control to the "FAST" position.
- 2.6 Select a slow gear. Engage the forward clutch. Control the ground speed by selecting the desired gear.

SECTION 3

Service Instructions

3.1 Lubrication:

1. Every eight hours of operation apply multi-purpose grease to the lube fittings on:
 - a. Each spindle (3)
 - b. Each gauge wheel (2)
 - c. Drive shaft
 - d. Front mount--quick hitch pin
 - each caster wheel (2)
 - each caster fork (2)
2. Gear Box: Once a year or every 200 hours of operation, check the lubricant by removing the cover. Clean the top of the gear box and carefully remove the cover. Replace the gasket if damaged. Keep the gear box $3/4$ full of grease.

3.2 Blade Service:

1. Every ten hours of operation or when the cut is poor visually, check the blades for sharpness.
2. Remove the mower from the tractor. See Sections 3.6 and 3.7.
3. Turn the mower upside down.
4. Block the blades and remove the nuts and flat washers from the spindle.
5. Sharpen and balance the blade.
6. Reverse the removal process to install the blades on mower and the mower on the tractor.
7. Replace the blades when over 1/2" has been removed or the blade cannot be balanced.

3.3 Height of Cut Adjustment: Lift up on the height adjustment lever and rotate the axle pivot weldment until the lever registers with the slot corresponding to the desired height of cut. The lowest cut position is when the lever is nearest the deck.

3.4 Belt Adjustment:

1. Remove the right belt cover.
2. Unlock the adjusting nuts. See Figure 1.
3. Rotate the inside nut until the air gap in the spring is .010" to .015" (.25mm to .38mm).
4. Jam the adjusting nuts.
5. Install the belt cover.

3.5 Belt Replacement:

1. Remove the mower from the tractor.
2. Remove the belt covers.
3. Loosen the spring tension on the belt.
4. Remove the gear housing support.
5. Remove the belt.
6. Put the new belt in position on the sheaves. See Diagram 1.
7. Mount the gear housing support.

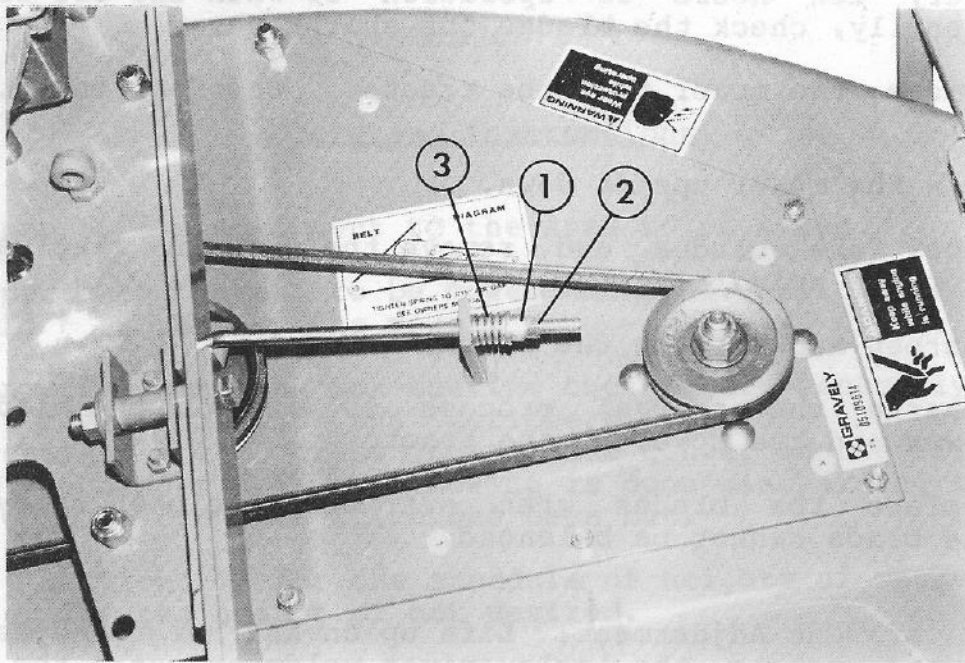

- 1 - Adjusting Nut
 - 2 - Jam Nut
 - 3 - Spring
- FIGURE 1

85012

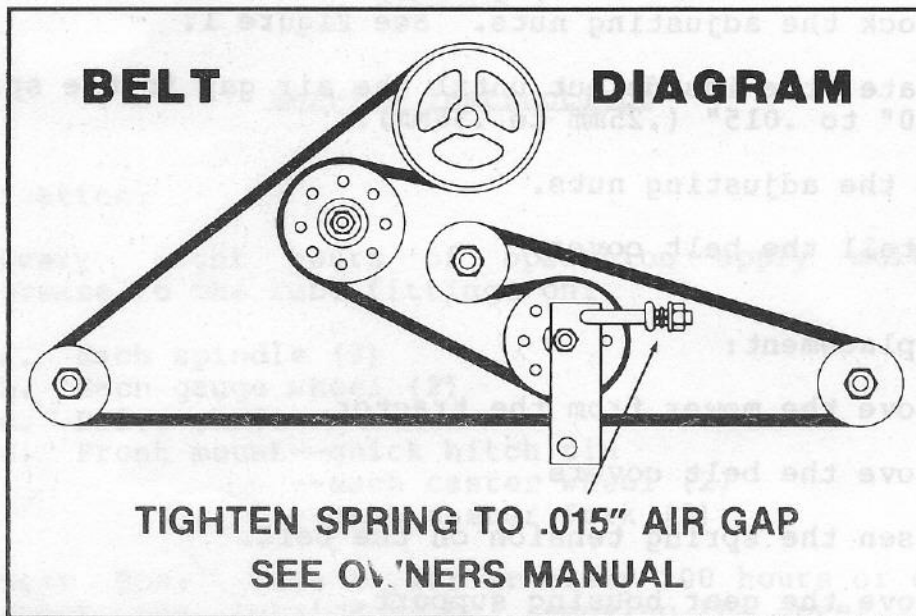

DIAGRAM 1

84020

8. Adjust the belt tension.
9. Install the belt covers.
10. Mount the mower on the tractor.

3.6 Mower Installation on the Two-Wheel Tractor:

1. Put a film of grease on the quick hitch pin. See Figure 2.
2. Slide the pivot support onto the quick hitch pin and retain with a flat washer and klik pin.
3. Put a film of grease on the shaft of the universal drive assembly. Slide the shaft into the tube of universal joint (female) assembly.
4. Pull (or rotate) the locking collar toward the U-joint and slide onto the tractor PTO shaft. Release the locking collar. Pull on the drive to make sure that the drive has locked in place.
5. To remove the mower, reverse the steps above.

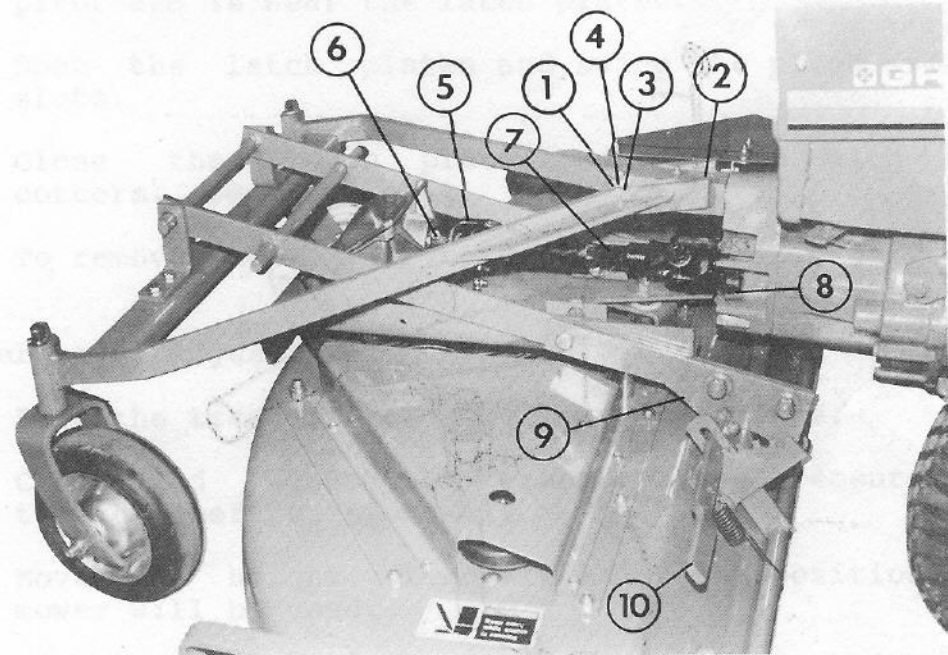

85013

- | | |
|---------------------|------------------------------|
| 1 - Quick Hitch Pin | 6 - U-Joint Retaining Bolt |
| 2 - Pivot Support | 7 - U-Joint Male |
| 3 - Flat Washer | 8 - Locking Collar |
| 4 - "Klik" Pin | 9 - Deck Leveling Cam |
| 5 - U-Joint Female | 10 - Height Adjustment Lever |

FIGURE 2

3.7 Mower Installation on the Four-Wheel Tractor:

1. Install the lift rod on the tractor as shown in Diagram 2.
2. Use the second hole in the end of the lift arm when mounting on a short frame tractor.
2. Put a film of grease on the shaft on the universal joint (male) assembly. Slide the shaft into the tube of the universal joint (female) assembly.
3. Put the height adjustment lever in the lowest cut position (near deck).
4. Position the tractor with the front wheels behind the mower.
5. Roll the front of the tractor over the mower. See Figure 3.
6. Put a film of grease on the PTO shaft.
7. Unlock the universal joint drive assembly locking collar by rotating or pulling toward the drive assembly. Slide the drive assembly on the PTO shaft and release the locking collar. Pull on the drive assembly to make sure it is locked on the PTO shaft.
8. Lower the attachment lift.

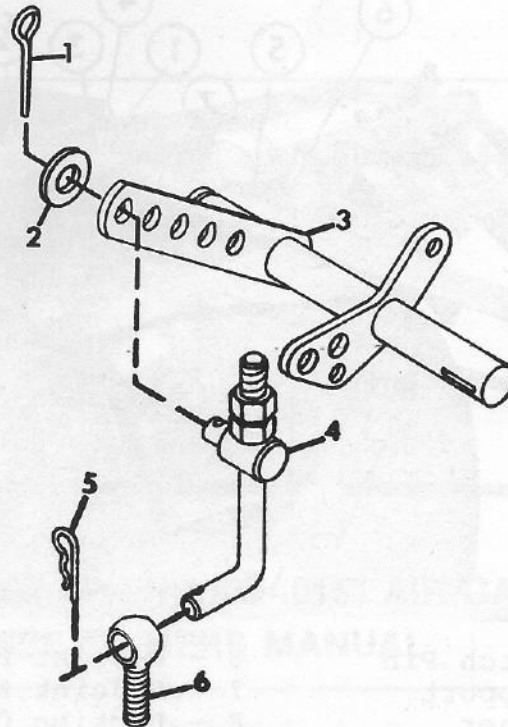

85021

- | | |
|-------------------------|----------------------|
| 1 - Cotter Pin | 4 - Mower Lift Pivot |
| 2 - Washer | 5 - Hair Pin Cotter |
| 3 - Lift Lever Weldment | 6 - Eye Bolt |

DIAGRAM 2



FIGURE 3

85014

9. Put the end of the lift rod in the eye bolt on the mower. Secure with a hair pin cotter.
10. Lift the mower with the attachment lift until the mower pivot arm is near the latch plates.
11. Open the latch plates and swing the pivot arm into the slots.
12. Close the latch plates and secure with hair pin cotters. See Figure 4.
13. To remove the mower, reverse the installation procedure.

3.8 Mower Level Adjustment:

1. Park the tractor on a level, paved surface.
2. Check and adjust the tractor tire pressure. See the tractor operator's manual.
3. Move the height of cut lever to the position where the mower will be used.
4. Loosen the bolts which retain the deck leveling cams.
5. Loosen the jam nut on the eccentric bolts which retain the gauge wheels.
6. Rotate the eccentric bolts in the gauge wheels until the distance from the rear of the deck to the supporting surface is equal on each side of the mower. See Diagram 3.

7. Adjust the deck leveling cams with the cam until the front edge of the deck to the supporting surface is within .1 inch of the rear distance. See Diagram 3. Readjustment of the eccentric bolt in the gauge wheel may be required.
8. Jam the nuts on the eccentric bolts and tighten the bolts which retain the deck leveling cams.

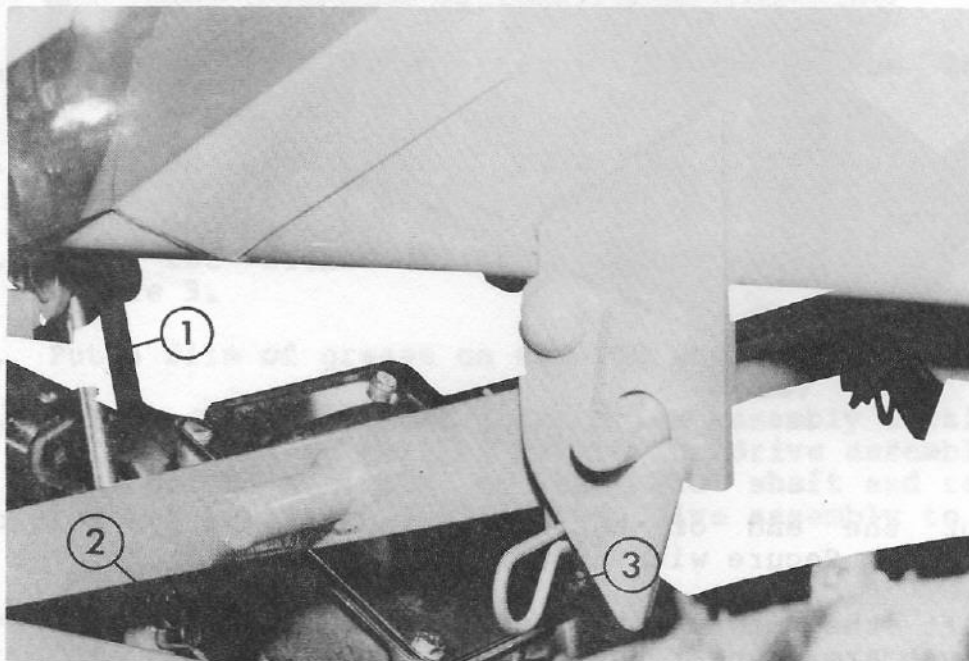

- 1 - Lift Rod
- 2 - Hair Pin Cotter
- 3 - Large Hair Pin Cotter

84024

FIGURE 4

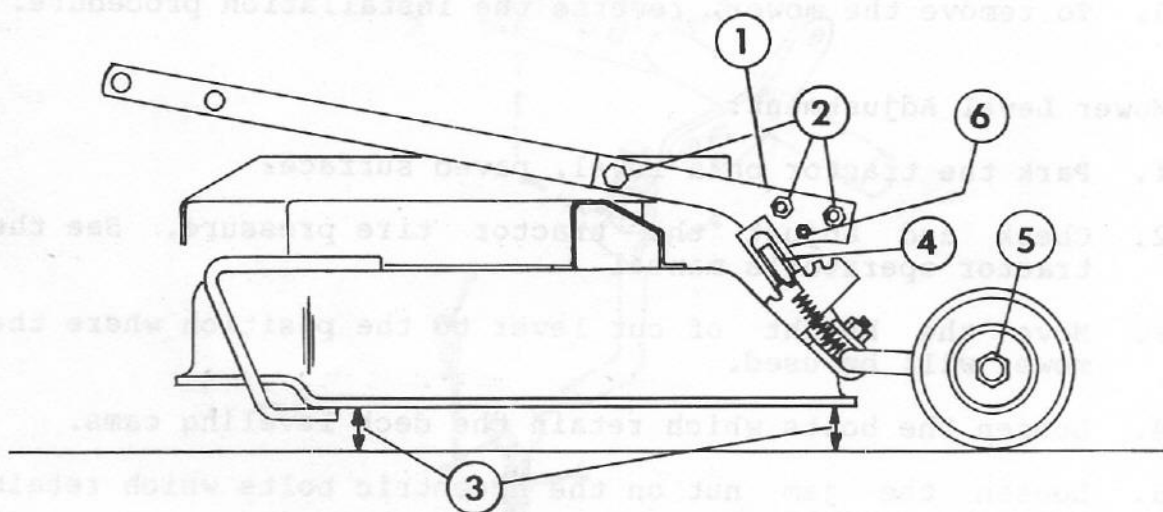

- 1 - Deck Leveling Cam
- 2 - Nuts
- 3 - Measure Height
- 4 - Height of Cut Lever
- 5 - Eccentric Bolt
- 6 - Cam

DIAGRAM 3

85020

SECTION 4

Storage

- 4.1 Remove the mower from the tractor and clean.
- 4.2 Inspect for damage, wear, loose or missing hardware. Repair as needed.
- 4.3 Sharpen and balance the blades.
- 4.4 Lubricate.
- 4.5 Paint any bare areas.
- 4.6 Place in a dry area.

SECTION 5

Solving Problems

Problem Chart:

<u>OBSERVATION</u>	<u>POSSIBLE CAUSE</u>
1. Uneven cut	Mower not level Uneven tractor tire pressure Damaged gauge wheel or axle Damaged pivot arm weldment Bent blade
2. Uncut grass	Dull blade Damaged blade Too low engine speed Mowing tall grass
3. Smoke from mower	Spindle/blade locked Debris wedged against belt Loose belt
4. Engine slows when mower is engaged	Damaged bearing in spindle assembly Damaged bearings/gears in the gear box
5. Excessive noise	Unbalanced blade(s) Damaged universal joint Damaged gear box bearings/gears Idler bearings Damaged bearings in spindle assembly

SECTION 6

Illustrated Parts and Parts List

40" MOWER DECK ASSEMBLY

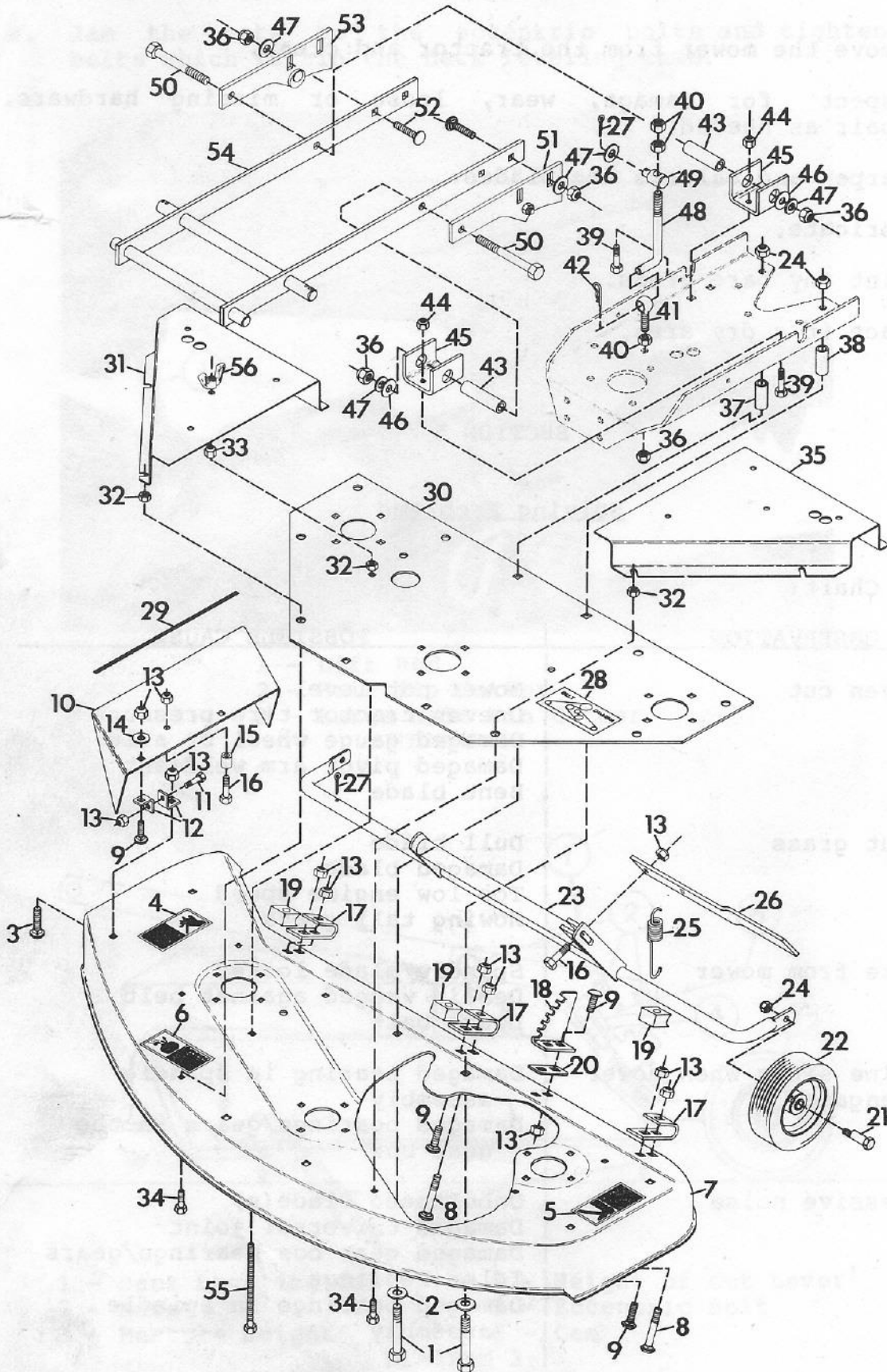

40" MOWER DECK ASSEMBLY

ITEM NO.	PART NO.	QTY.	DESCRIPTION
1	180193	4	Bolt, Hex 1/2-13x3.75
2	120396	4	Washer, Flat .531x1.062x.095
3	126227	2	Bolt, Carriage 3/8-16x.75
4	33926	1	Decal, Danger Hand
5	33927	1	Decal, Danger Foot
6	33928	1	Decal, Warning Eye
7	34438	1	Weldment, 40 in. Deck
8	126419	3	Bolt, 3/8-16x2 Rd Hd Sq Nk
9	120915	7	Bolt, 3/8-16x1 Rd Hd Sq Nk
10	38697	1	Chute, 40" Flip-Up
11	180121	2	Bolt, Hex 3/8-16x.875
12	34894	4	Tab, Spring
13	456004	16	Nut, Lock 3/8-16
14	120394	2	Washer, Flat .406x.812x.065
15	38696	1	Stop, Chute
16	180126	2	Bolt, Hex 3/8-16x1.50
17	11264	3	Bracket, Axle Support
18	11265	1	Bracket, Height Adjust
19	11260	3	Stop, Nylon
20	21462	1	Shim, Mower Ht. Adj. Bkt.
21	38985	2	Bolt, Eccentric
22	34426	2	Wheel, Gauge
23	38999	1	Weldment, Axle Pivot
24	435507	6	Nut, Lock 1/2-13
25	21471	1	Spring, 40 and 50 Inch Mower
26	38990	1	Lever, Height of Cut
27	120123	2	Pin, Cotter 1/8x1.25
28	11715	1	Decal, Belt Installation
29	38769	1	Stripe
30	34195	1	Plate, Support
31	21258	1	Cover, Pulley R.H. 40
32	124824	10	Nut, Jam 5/16-18 Hex
33	419455	2	Nut, Lock 5/16-18
34	180077	8	Bolt, Hex 5/16-18x.75
35	21257	1	Cover, Pulley L.H. 40
36	414074	7	Nut, Lock 1/2-13
37	34119	1	Spacer
38	19348	3	Spacer, .510x.840x2.43
39	180078	4	Bolt, Hex 5/16-18x.875
40	120238	3	Nut, Jam 1/2-13 Hex
41	19350	1	Bolt, Eye
42	15691	1	Pin, Cotter Hair
43	22414	2	Bushing, Mower Pivot .510x.750
44	413447	4	Nut, Lock 5/16-18
45	22415	2	Support, Mower Pivot
46	423315	2	Washer, Flat .813x1.37x.100
47	415543	7	Washer, Flat .531x1.250x.100
48	19201	1	Rod, Lift
49	40625	1	Pivot, Mower Lift
50	180191	2	Bolt, Hex 1/2-13x3.25
51	38988	1	Weldment, Deck Leveling L.H.
52	126485	4	Bolt, Carriage 1/2-13x1.25
53	38986	1	Weldment, Deck Leveling R.H.
54	38992	1	Weldment, Pivot Arm
55	40193	2	Bolt, Hex 5/16-18x3.50
56	40194	2	Nut, Wing 5/16-18

50" MOWER DECK ASSEMBLY

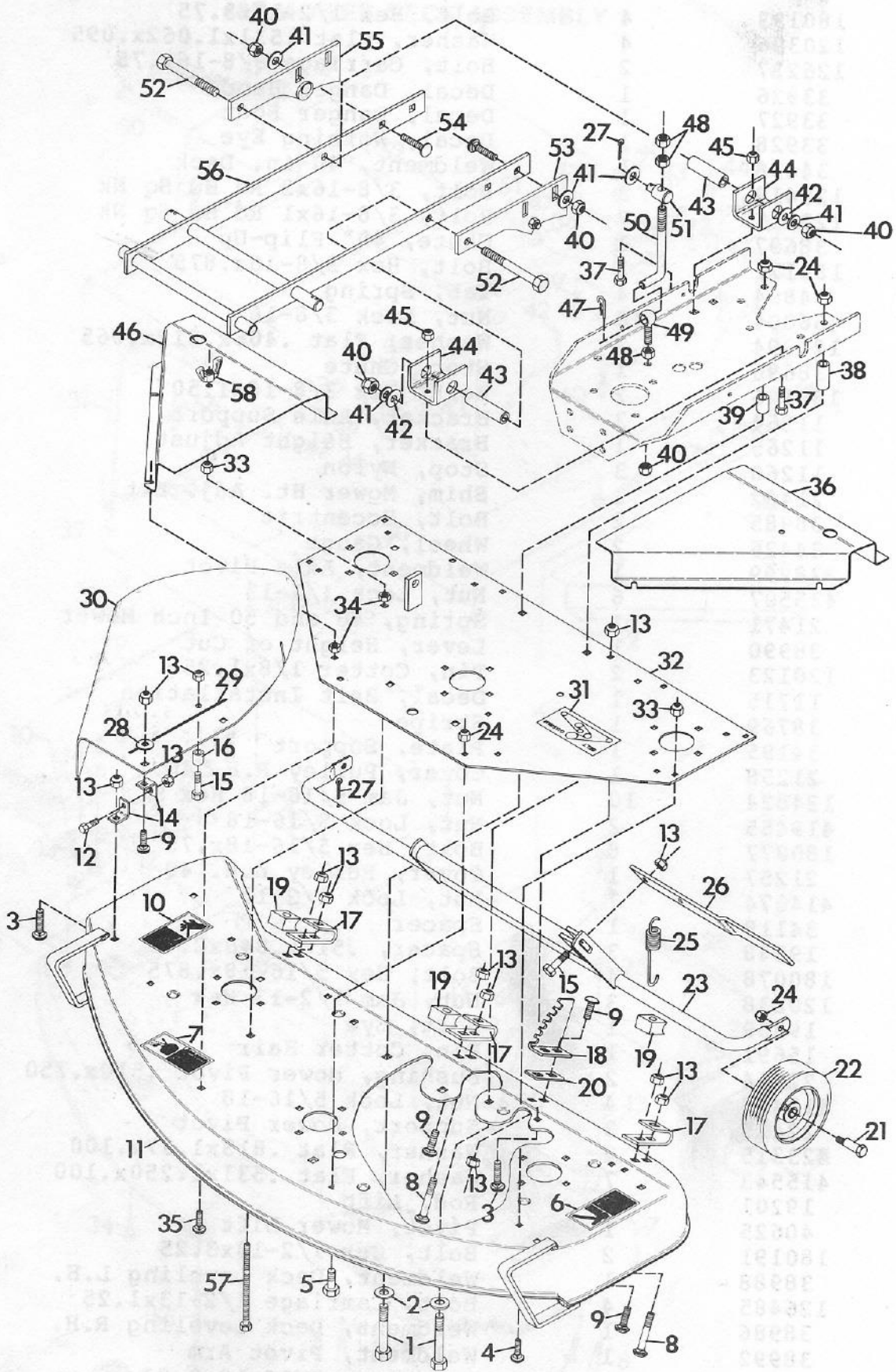

50" MOWER DECK ASSEMBLY

ITEM NO.	PART NO.	QTY.	DESCRIPTION
1	180193	4	Bolt, Hex 1/2-13x3.75
2	120396	4	Washer, Flat .531x1.062x.095
3	126227	4	Bolt, Carriage 3/8-16x.75
4	126216	6	Bolt, Carriage 5/16-18x.75
5	180175	2	Bolt, Hex 1/2-13x1.25
6	33927	1	Decal, Danger Foot
7	33928	1	Decal, Warning Eye
8	126419	3	Bolt, 3/8-16x2 Rd Hd Sq Nk
9	120915	7	Bolt, 3/8-16x1 Rd Hd Sq Nk
10	33926	1	Decal, Danger Hand
11	35181	1	Weldment, 50 Inch Deck
12	180121	2	Bolt, Hex 3/8-16x.875
13	456004	18	Nut, Lock 3/8-16
14	34894	4	Tab, Spring
15	180126	2	Bolt, Hex 3/8-16x1.50
16	38696	1	Stop, Chute
17	11264	3	Bracket, Axle Support
18	11265	1	Bracket, Height Adjust
19	11260	3	Stop, Nylon
20	21462	1	Shim, Mower Ht. Adj. Brkt.
21	38985	2	Bolt, Eccentric
22	34426	2	Wheel, Gauge
23	38993	1	Weldment, Axle Pivot
24	435507	8	Nut, Lock 1/2-13
25	21471	1	Spring, 40 and 50 Inch Mower
26	38990	1	Lever, Height of Cut
27	120123	2	Pin, Cotter .125x1.250
28	120394	2	Washer, Flat .406x.812x.065
29	38769	1	Stripe
30	38675	1	Shield, Safety Extension
31	11715	1	Decal, Belt Installation
32	35179	1	Weldment, Support Plate
33	419455	8	Nut, Lock 5/16-18
34	124824	10	Nut, Jam 5/16-18 Hex
35	126211	8	Bolt, 5/16-18x.625 Rd Hd Sq Nk
36	21259	1	Cover, Pulley L.H.
37	180078	4	Bolt, Hex 5/16-18x.875
38	19348	3	Spacer, .510x.840x2.43
39	34119	1	Spacer
40	414074	7	Nut, Lock 1/2-13
41	415543	7	Washer, Flat .531x1.250x.100
42	423315	2	Washer, Flat .813x1.37x.10
43	22414	2	Bushing, Pivot .510x.750x2.020
44	22415	2	Support, Mower Pivot
45	413447	4	Nut, Lock 5/16-18
46	21260	1	Cover, Pulley R.H.
47	15691	1	Pin, Cotter Hair
48	120238	3	Nut, Jam 1/2-13 Hex
49	19350	1	Bolt, Eye
50	19201	1	Rod, Lift
51	40625	1	Pivot, Mower Lift
52	180191	2	Bolt, Hex 1/2-13x3.25
53	38988	1	Weldment, Deck Leveling L.H.
54	126485	4	Bolt, Carriage 1/2-13x1.25
55	38986	1	Weldment, Deck Leveling R.H.
56	38992	1	Weldment, Pivot Arm
57	40193	2	Bolt, Hex 5/16-18x3.50
58	40194	2	Nut, Wing 5/16-18

MOWER DRIVE 40" & 50"

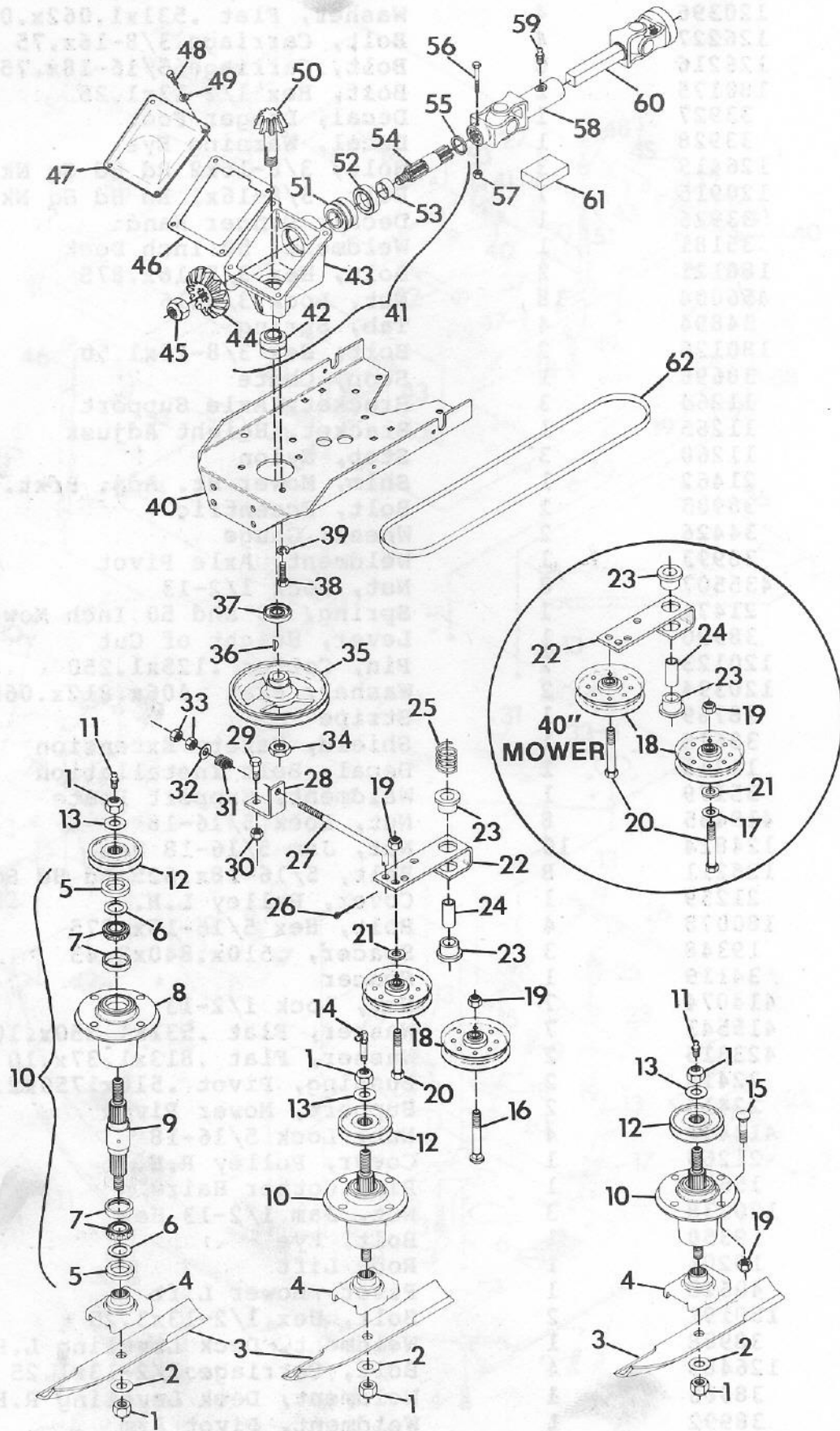

MOWER DRIVE 40" & 50"

ITEM NO.	PART NO.	QTY.	DESCRIPTION
1	418692	6	Nut, Lock 5/8-11
2	131016	3	Washer, Flat .656x1.312x.095
3	11234	3	Blade, 50" Mower (Standard)
	38947	3	Blade, 50" Double Edge (Optional)
	14668	3	Blade, 40" Mower
4	23026	3	Weldment, Blade Cradle
5	21211	2	Seal, Steel
6	20743	2	Washer, Flat .975x1.970x.030
7	38199	2	Assembly, Bearing
8	21215	1	Housing, Bearing
9	21216	1	Shaft, Spindle
10	21306	3	Assembly, Spindle
11	411010	2	Fitting, Lube 1/8
12	34428	3	Sheave, Spindle 40" Mower
	20065	3	Sheave, Spindle 50" Mower
13	33845	3	Washer, Flat .687x1.312x.122/.146
14	21214	1	Fitting, Lube .125 Ext. 90 Deg.
15	126402	12	Bolt, 3/8-16x1.25 Rd Hd Sq Nk
16	126416	1	Bolt, 3/8-16x1.75 Rd Hd Sq Nk
17	120388	1	Washer, Flat .438x1.000x.083
18	21060	2	Sheave, Idler
19	456004	14	Nut, Lock 3/8-16
20	180130	2 (40") 1 (50")	Bolt, Hex 3/8-16x2.00
21	14672	1	Spacer, Idler .406x.750x.188
22	34120	1	Arm, Idler Pivot
23	10174	2	Bushing, Nylon .760x1.000x.600
24	34119	1	Spacer
25	20444	1	Spring, Comp.
26	121224	1	Pin, Cotter 3/32x1.00
27	21111	1	Rod, Idler 50" Mower
	21112	1	Rod, Idler 40" Mower
28	34431	1 (40")	Support, Spring
29	180177	1 (40")	Bolt, Hex 1/2-13x1.50
30	435507	1 (40")	Nut, Lock 1/2-13
31	11779	1	Spring, Comp. 1x.78x338 Lb/In
32	120394	1	Washer, Flat .406x.812x.065
33	120369	2	Nut, Hex 3/8-24
34	451539	1	Nut, Jam 3/4-10 Hex Heavy
35	14660	1	Sheave, 1/2x6.50
36	431787	1	Key, Woodruff .188x.625 Hard #61
37	14645	1	Seal, Oil 1.250x1.686x.313
38	180173	3	Bolt, Hex 1/2-13x1
39	120384	3	Washer, Lock 1/2 Reg.
40	34924	1	Support, Gear Housing
41	31410	1	Assembly, Drive
42	14644	1	Assembly, Bearing .750x1.781x.499
43	14636	1	Casting, Gear Box
44	19607	1	Gear, Bevel
45	456007	1	Nut, Lock 3/4-10
46	11231	1	Gasket, Gear Housing
47	10982	1	Cover, Gear Housing
48	180016	4	Bolt, Hex 1/4-20x.50
49	120380	4	Washer, Lock 1/4 Reg.
50	19608	1	Shaft, Gear Pinion

MOWER DRIVE 40" & 50"

ITEM NO.	PART NO.	QTY.	DESCRIPTION
51	14640	1	Assembly, Bearing 1.000x1.980x1.243
52	14646	1	Seal, Oil 1.250x1.987x.250
53	14641	1	Spacer
54	31412	1	Shaft, Drive
55	14642	1	Ring, Retaining 1.000 Shaft
56	180044	1	Bolt, Hex 1/4-20x2
57	419454	1	Nut, Lock 1/4-20
58	13518	1	U-Joint, Female End
59	411027	1	Fitting, Lube 1/4-28
60	19074	1	Shaft, Prop. Sq. Bar
61	12134	1	Kit, Repair U-Joint (Rock. Std.)
	24560	1	Kit, Repair U-Joint (Neapco)
62	34429	1	Belt, 40" Mower
	11216	1	Belt, V .500x.312x126.3

NOTE: Parts shown in circle pertain to 40" mower.

SECTION 7

Specifications

<u>ITEM</u>	<u>40" MOWER</u>	<u>50" MOWER</u>
Width of Cut:	40" (1016mm)	50" (1270mm)
Heights of Cut:	1.5" (38mm) 2.0" (51mm) 2.5" (64mm) 3.0" (76mm) 3.5" (89mm) 4.0" (102mm)	
No. of Spindles/Blades:	3	3
Weight:	207 lbs. (93.8kg)	263 lbs. (119.3kg)
Width:	50.5" (1283mm)	62" (1575mm)
Height:	15" (381mm)	15" (381mm)
Length:	35" (889mm)	35" (889mm)

SECTION 8

Set-Up Instructions

- 8.1 Remove the mower from the shipping container.
- 8.2 Put the axle pivot in position in the axle support brackets. See Figure 5.
- 8.3 Put a nylon stop in each axle support bracket with the curved end against the axle pivot. Secure the nylon stops with 3/8-16x2" carriage bolts from under the deck and 3/8-16 lock nuts.
- 8.4 Install a cotter pin in the axle pivot as shown in Figure 6.
- 8.5 Put the height of cut lever in position on the axle pivot weldment. Secure with a 3/8 bolt from the front side and 3/8 lock nut. See Figure 7.
- 8.6 Install the spring from the axle pivot weldment to the height of cut lever.

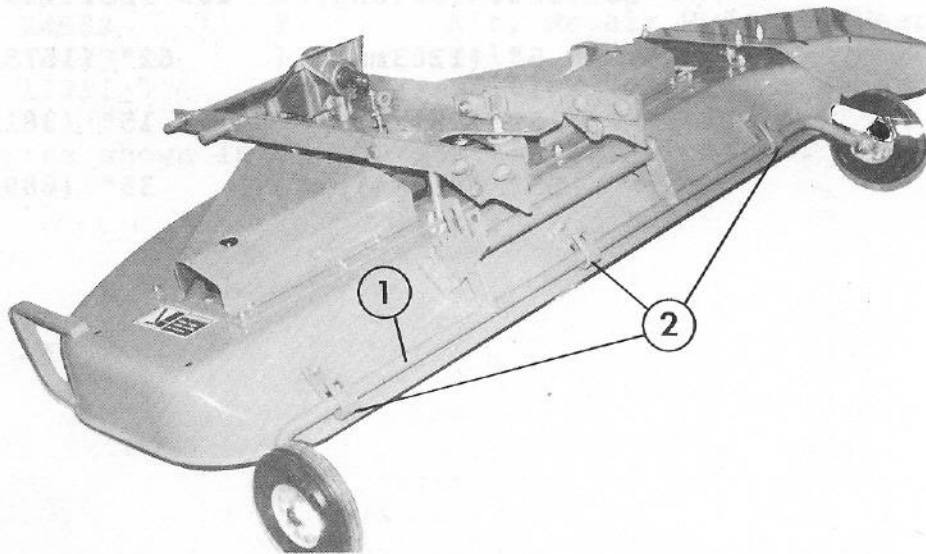

1 - Axle
2 - Axle Support Bracket
FIGURE 5

85015

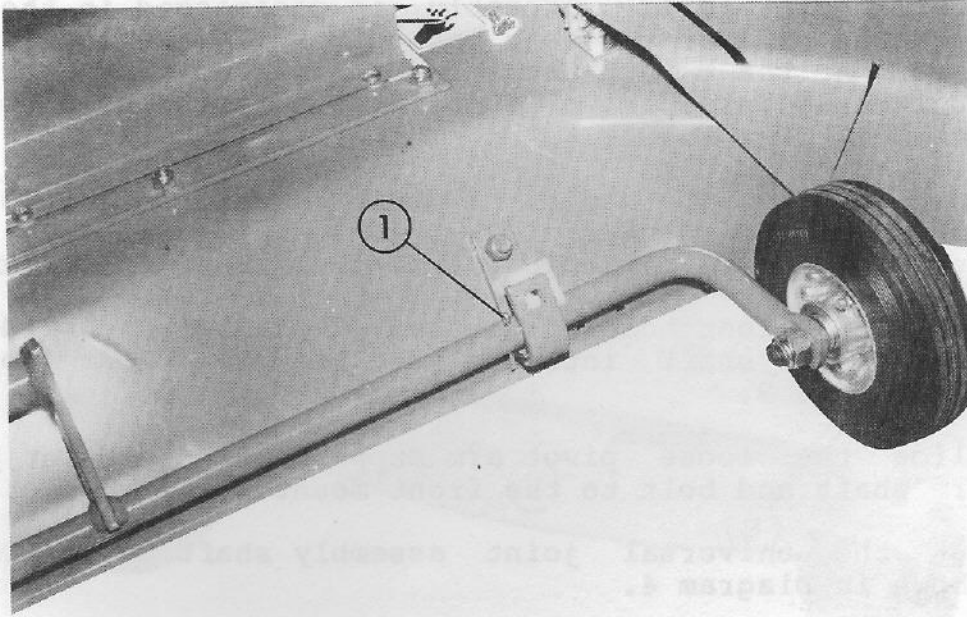

1 - Cotter Pin
FIGURE 6

85016

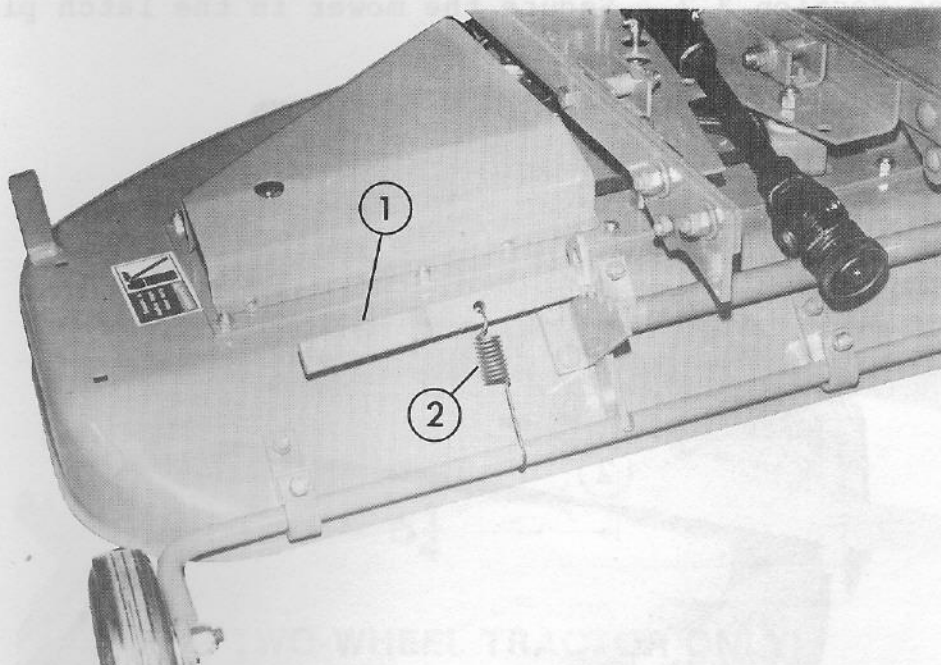

1 - Height Adjustment Lever
2 - Spring

FIGURE 7

85017

- 8.7 If the mower is to be used on a long frame tractor, the universal joint drive assembly is positioned in the hole nearest the end of the gear box shaft. If the mower is to be used on the short frame tractor or two-wheel tractor, the universal joint drive is positioned in the hole nearest the gearbox. See Figure 8.
- 8.8 To mount the mower to the front mount (two-wheel tractor):
1. Remove a pivot arm support from the front mount frame.
 2. Put the front mount frame over the mower and slide the pivot arm shaft into the remaining pivot arm support. See Figure 9.
 3. Slide the loose pivot arm support on the vacant pivot arm shaft and bolt to the front mount frame.
 4. Cut the universal joint assembly shaft to the length shown in Diagram 4.
- 8.9 The mower lift rod is installed and adjusted the first time the mower is mounted on the four-wheel tractor.
1. Put the lift pivot on the lift rod followed by two jam nuts. Leave the nuts loose for adjustment. See Diagram 5.
 2. See Section 3.7. Secure the mower in the latch plates.

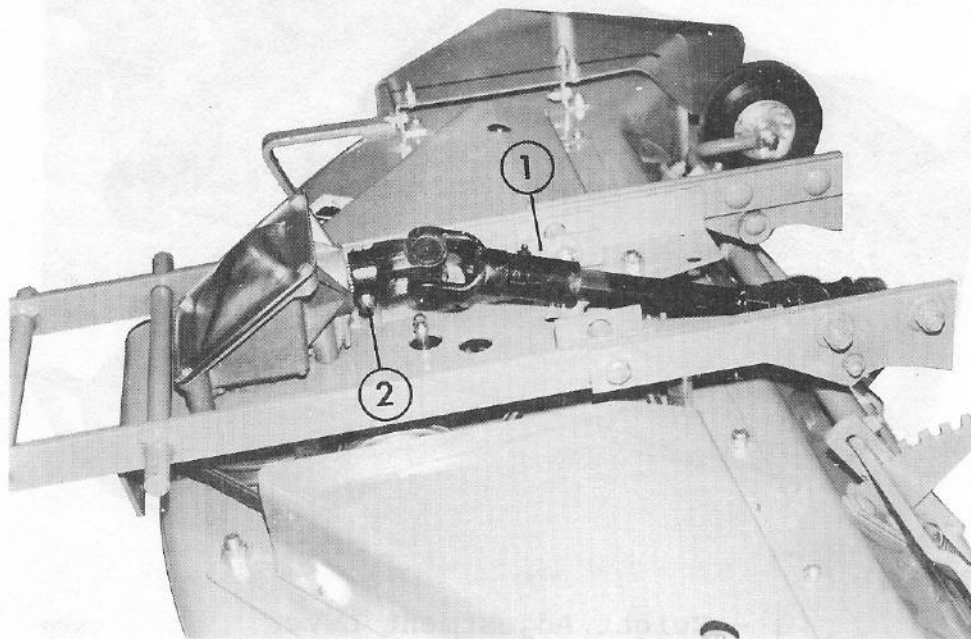

1 - U-Joint Female
2 - Retaining Bolt
FIGURE 8

85018

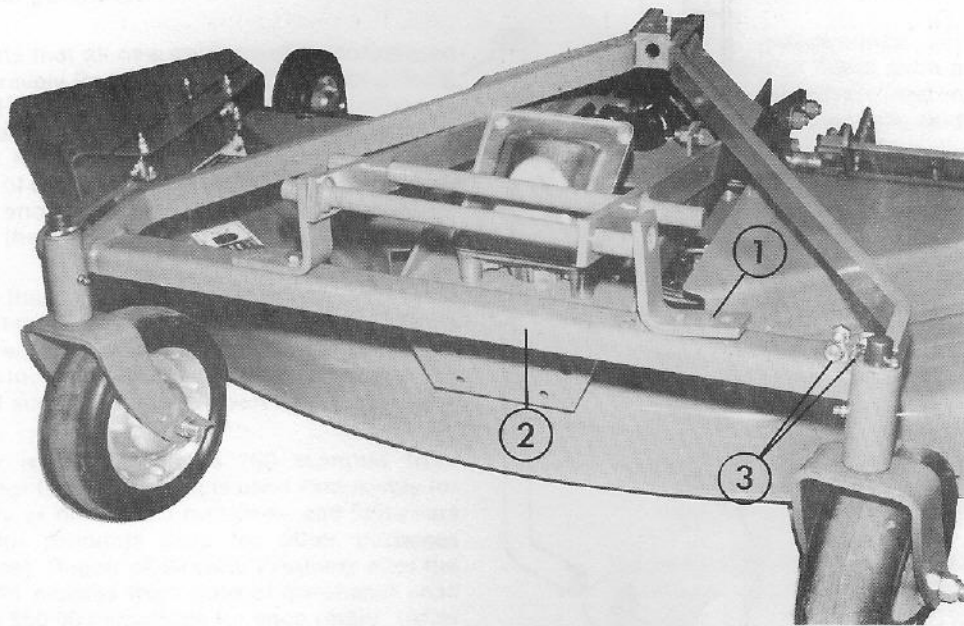

- 1 - Pivot Arm Support
- 2 - Front Mount Frame
- 3 - Retaining Bolts

85019

FIGURE 9

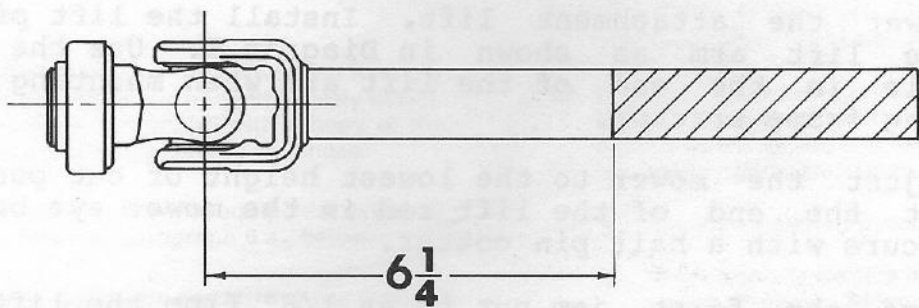

(FOR TWO-WHEEL TRACTOR ONLY)

DIAGRAM 4

84029

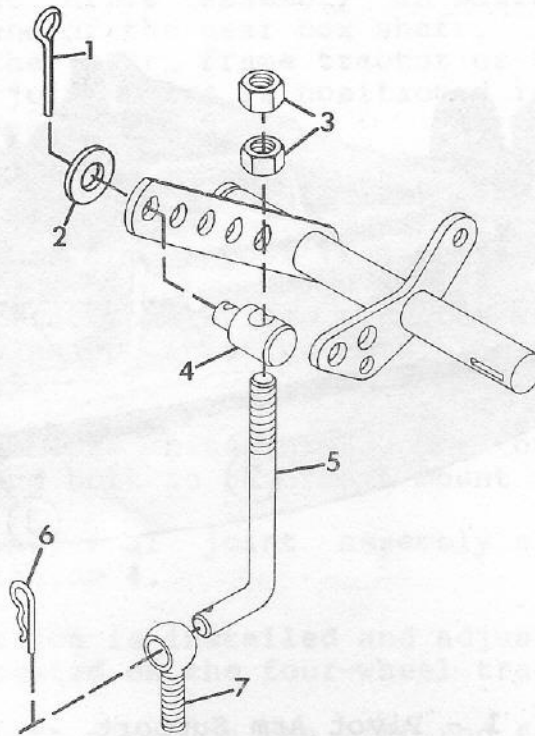

85022

- | | |
|----------------------|---------------------|
| 1 - Cotter Pin | 5 - Lift Rod |
| 2 - Washer | 6 - Hair Pin Cotter |
| 3 - Jam Nuts | 7 - Eye Bolt |
| 4 - Mower Lift Pivot | |

DIAGRAM 5

3. Lower the attachment lift. Install the lift pivot in the lift arm as shown in Diagram 5. Use the second hole in the end of the lift arm when mounting on the long frame tractor.
 4. Adjust the mower to the lowest height of cut position. Put the end of the lift rod in the mower eye bolt and secure with a hair pin cotter.
 5. Move the first jam nut to an 1/8" from the lift pivot and lock it in place by jamming with the second nut.
 6. Follow Section 3.7 for installation and removal of the mower on the tractor.
- 8.10 Level the mower the first time that it is mounted to the tractor. See Section 3.8.

LIMITED FIVE-YEAR WARRANTY

1. This Limited Five-Year Warranty is issued by Gravely International, Inc., only to the original purchaser. If Gravely equipment is leased by Gravely, this Warranty shall extend also to the original lessee as if such lessee were the original purchaser.
2. Gravely warrants that all new equipment manufactured by Gravely ("Gravely Products") shall be free of defects in material and workmanship for the term described in paragraph 4, below. Except as hereinafter provided, this Warranty does not cover any engine, tires or battery forming a part of the Gravely Product. Engine and tires are covered by and subject to separate warranties of the manufacturers thereof.
3. In the event that any Gravely Product warranted hereunder shall be defective or fail to conform with this Warranty, Gravely shall, subject to the provisions hereof, pay for, or provide labor and materials for, the repair or replacement of such defective Gravely Product.
4. This Warranty is for five years (60 months) from purchase date for Gravely Products used exclusively for personal, family or household purposes, and two years (24 months) for products used for other purposes (commercial use). Repair of Gravely Products after the second year (24 months from date of purchase) shall be subject to a \$50.00 deductible for each repair. (After two years, Gravely agrees to repair or replace defective Gravely Products used exclusively for personal, family or household purposes only to the extent that the cost of such repair or replacement exceeds \$50.00.)

Batteries are warranted by Gravely for a period of twelve (12) months only. If a battery shall fail within twelve (12) months of purchase, the replacement cost thereof shall be prorated over a twelve-month term based upon the number of months since purchase.
5. To obtain Warranty Service on a Gravely Product (including any battery or other component not manufactured by Gravely), use this procedure:
 - a. Notify the Gravely dealer from whom you purchased the equipment.
 - b. If you have moved and it is not convenient to notify the selling dealer, notify the nearest Gravely dealer. You should supply this dealer with a copy of the bill of sale as proof of the date of purchase.
 - c. Make arrangements to have the equipment delivered to the dealer (refer to paragraph 6 a., below).
 - d. If you have any questions concerning the Gravely Limited Warranty, they should be referred to:

Gravely International, Inc.
One Gravely Lane
Clemmons, NC 27012
Attn: Customer Service Department
 - e. Warranty service on Gravely Products must be performed by an authorized Gravely dealer.
6. This Warranty does not cover the following:
 - a. Transportation to the Gravely dealership. (If the Gravely dealer provides transportation, he will charge for such service.)
 - b. Normal maintenance services and normal replacement of items such as spark plugs, belts, oil, oil filters, air filters, and mower, plow or cultivator blades, gauge wheels, skids and other wear items.
 - c. Any Gravely Product which has been altered or modified in any way.
 - d. Any repair or replacement occasioned by customer neglect or lack of proper maintenance. (The purchaser is responsible for making sure that Gravely Products are operated and serviced as directed in the applicable manual or service instruction. Incorrect use or maintenance will void this Warranty.)
 - e. Any repair occasioned by the use of any attachment not approved by Gravely. (The use of any such unapproved attachment will void this Warranty.)
7. GRAVELY MAKES NO OTHER EXPRESS OR IMPLIED WARRANTIES, OR WARRANTIES AS TO THE MERCHANTABILITY OR FITNESS FOR A PARTICULAR PURPOSE. ALL WARRANTIES ARE LIMITED IN DURATION TO THE TERMS SET OUT IN PARAGRAPH 4, ABOVE. GRAVELY SHALL HAVE NO LIABILITY FOR INCIDENTAL OR CONSEQUENTIAL DAMAGES RESULTING FROM THE BREACH OF ANY WARRANTY, INCLUDING, BUT NOT LIMITED TO, LIABILITY FOR INCONVENIENCE, RENTAL OR PURCHASE OF REPLACEMENT EQUIPMENT, OR FOR LOSS OF PROFITS OR OTHER COMMERCIAL LOSS.
8. Some states do not allow limitations on how long an implied warranty lasts, so the above statement may not apply to you. Some states do not allow the exclusion or limitation of incidental or consequential damages, so the above limitation or exclusion may not apply to you.
9. This Warranty gives you specific legal rights, and you may have other rights which vary from state to state.
10. A Gravely product registration card is supplied with each Gravely Product. Please complete the card and return it to Gravely at the address listed on the card. The equipment registration card will be used by Gravely for:
 - a. Recording date of purchase.
 - b. Notification of owners in compliance with the Consumer Product Safety Act, should any notification be necessary.The return of such card is necessary for your warranty to be effective.
11. This Warranty is not subject to change or modification by anyone, including Gravely dealers and no Gravely dealer is authorized to make any representations or promises on Gravely's behalf.



One Gravely Lane, Clemmons, NC 27012